

SRN-2000W/PCN

Super-Red Wireless PIR



Installation Instructions

1. INTRODUCTION

1.1 General Description

The SRN-2000W/PCN wireless PIR is an advanced micro-processor-controlled, low-current PIR detector incorporating an on-board miniature UHF transmitter. Both PIR and transmitter are powered by an internal 9 Volt alkaline battery housed within the detector's case.

Following detection, the SRN-2000W/PCN activates the plug-in UHF transmitter for 2 seconds, then disarms itself to save battery power. The detector rearms itself automatically (reverts to the ready state) 2 minutes after the last movement has been detected. For convenience, a unique TEST/NORMAL selector is used to override the 2-minute rearm timer during walk testing.

1.2 Features

- Microprocessor-controlled
- 9 Volt battery powered, with unique energy saving circuitry
- Extremely-low current consumption – 0.013 mA
- Automatic low-battery and tamper alerts
- On-board CE and FCC approved transmitter module
- Programmable system and channel codes
- 45 easy-to-change lenses
- Programmable Pulse Counter
- Visible pattern locator option
- 25° vertical and 30° horizontal pattern calibration
- Surface and corner mounting
- Diverse swivel mounting brackets
- SMD technology
- Rejects RF interference up to 1000 MHz

1.3 Lens Selection

Coverage

The standard lens supplied with the SRN-2000W/PCN is No. 100 (see detailed specifications below and fig.1). Coverage patterns of all other interchangeable lenses are provided in the SUPER-RED lens library catalog. Your nearest VISONIC LTD. distributor will be glad to supply you with the lens that suits your particular requirements.

Lens No. 100 Specifications

Total Number of Beams: 36

Layers: Upper, Intermediate and Downward.

Upper Layer - 9 twin beams, optically split to 18 beams.

Intermediate Layer - 5 twin beams (split), angled 10° below Upper Layer.

Downward Layer - 4 twin beams (split), angled 25° below Upper Layer.

Field of View: 90° Wide Angle.

Coverage range: maximum 18 x 18 m (60 x 60 ft).

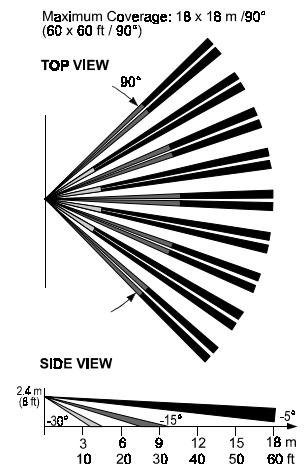

Figure 1. Coverage Pattern
- Lens No. 100

2. SPECIFICATIONS

OPTICAL

Standard Lens: Lens No. 100.

Interchangeable Lenses: See SUPER-RED Lens Library.

Adjustment: Vertical +10° to -15° calibrated scale.

Horizontal up to 30°.

ELECTRICAL

Voltage: 9 Volt alkaline or lithium battery.

Standby Current: 0.013 mA.

LED: Walk Test and transmission.

Detector: Dual-element low-noise pyroelectric sensor.

Pulse Counter: Programmable to 1, 2, 3 or 5 pulses with walk-test override.

Rearm Timer: Rearms the unit about 2 minutes after the last alarm; timer disabled in the walk test mode.

WIRELESS

Frequency (MHz): 315, 304, 404, 418, 433.92 or other frequencies according to local requirements.

Alarm Transmission Duration: 2 seconds.

Encoding: 8-bit digital word, 256 combinations, pulse width modulation.

Channels: 4 channels, switch selectable.

Battery Test: Automatic transmission of "Code 0" at 2-minute intervals if battery voltage drops below 7 V.

Tamper Alert: Transmission of the "Channel 2" code at 2-minute intervals, until the tamper switch is restored.

ENVIRONMENTAL

Operating Temperature: -10°C to 50°C (14°F to 122°F).

Storage Temperature: -20° to 60°C (-4°F to 140°F).

RFI Protection: Greater than 20 V/m up to 1000 MHz.

Note: The temperature range may be reduced due to battery characteristics.

PHYSICAL

Dimensions (H x W x D): 12 x 7 x 4.8 cm (4-3/4 x 2-3/4 x 1-7/8 in)

Weight: 95 g (3.4 oz).

Color: White.

OPTIONAL MOUNTING ACCESSORIES

SRF-201: Flush mounting adapter.

SRS-202: Mounting base for portable applications.

BR-1: Swivel bracket for wall mounting.

BR-2: BR-1 + corner mounting adapter.

BR-3: BR-1 + ceiling mounting adapter.

3. INSTALLATION

3.1 Changing Lenses

To change or adjust a lens, remove the front cover of the detector, as explained in Section 3.3. Release and remove the lens retainers located on both sides of the lens by pushing them from the inner side of the cover (Fig. 2).

Insert a new lens with the grooved surface facing out and the lens number in the upper right corner. From inside the cover, carefully center the lens by sliding it right or left, until it edges protrude equally at both sides.

Holding the lens firmly in place, insert the lens retainers from the front (ridges pointed outward) and firmly push them into place until a click is heard (Fig. 3).

3.2 Selecting the Mounting Location

The SRN-2000W/PCN wireless PIR can be mounted directly onto the wall (surface mounted), or in a corner. It may also be flush mounted, using the optional flush mounting bracket SRF-201 (Fig. 4). Always mount the unit on a firm and stable surface. A special stand - the SRS-202 (Fig. 5) -

enables you to put the SRN-2000 W/PCN on horizontal surfaces such as shelves, tables, etc. for temporary installation or portable applications where the detector location should be changed frequently. The SRS-202 can be fixed permanently to the horizontal surface, using the 2 screw holes at its bottom (Fig. 5). It may also be fixed to a vertical surface, provided that a strong adhesive is used.

A. Select the mounting location so that the expected motion of an intruder will cross the beams of the coverage pattern provided by the lens in actual use.

It is recommended to aim the PIR detector toward the coolest place in the protected area, in order to obtain the maximum sensitivity where high ambient temperatures are expected.

B. Select the most convenient mounting height.

You may mount the unit anywhere from ground level up to 5 m (17 ft).

C. Where a single-layer pattern has been selected because pets are present, it is advisable to install the unit as low as possible - usually 1.2 - 1.5 m (4 - 4.5 ft) - while still allowing the beams to be directed above the level of the pet's activity.

D. The SRN-2000W/PCN detectors are extremely immune to air turbulence and RF interference. However, to minimize false alarms, it is highly recommended to avoid aiming the detector at heaters, sources of bright light, or windows subjected to direct sunlight.

3.3 Mounting

A. To open the cover, insert a small screwdriver into the slot on top of the unit (Fig. 6). Press the blade in slightly between the cover and the base and lever backwards. The top part of the cover (equipped with the lens) will snap free.

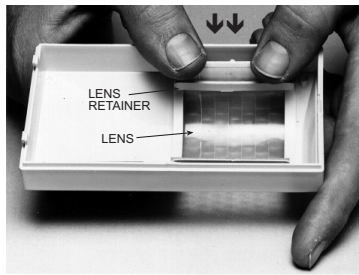

Figure 2. Lens Retainer Removal

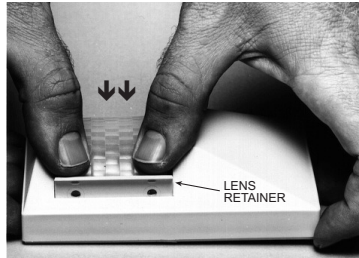

Figure 3. Locking the Lens in Place

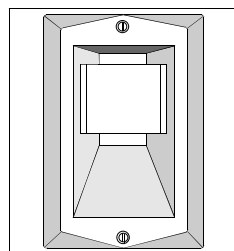

Figure 4. SRF-201

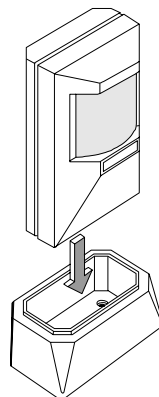

Figure 5. SRS-202

An accurate adjustment table determines the recommended angle for any combination of range and mounting height (see Table 1). Take into account that installations at increased height result in larger blind areas close to the detector.

You may now hinge the top of the cover outward, separate the bottom legs of the base from the slots in the cover and remove the cover.

B. Mount the base (equipped with the printed circuit board) in the location and height selected for optimum coverage.

For surface mounting use the two knockouts at the back of the base; for corner mounting, use the knockouts on the angled sides (Fig. 7).

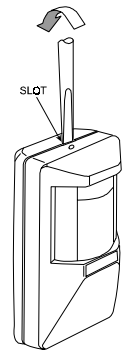

Figure 6. Cover Removal

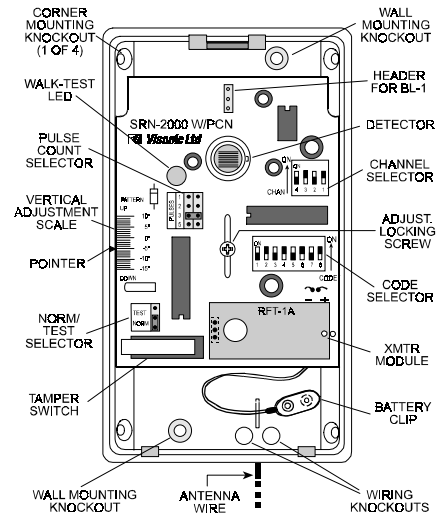

Figure 7. Components Layout

The unit must be fastened tightly to the mounting surface to avoid possible vibrations.

C. To close the case, insert the legs located on the bottom of the base into their respective slots in the bottom of the cover. Then close by exerting slight upward pressure on the cover (see Fig. 8).

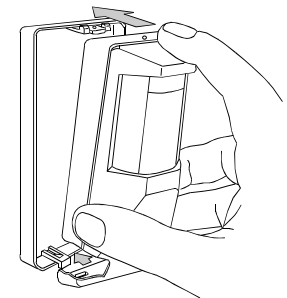

Figure 8. Replacing the Cover

3.4 Swivel Brackets (optional)

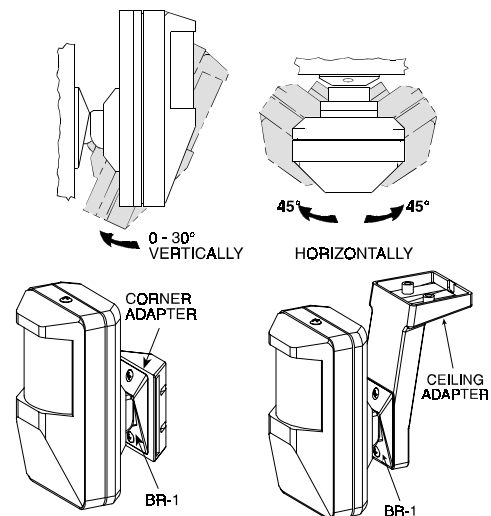

Figure 9. Optional Swivel Brackets

The BR-1 is a swivel, surface-mounted bracket used for greater flexibility when setting the desired detection range. The BR-1 is adjustable 30° downward and 45° left, 45° right.

The BR-2 is a swivel bracket kit for room corners. It consists of the BR-1 and a corner mounting adapter.

The BR-3 is a swivel bracket kit for ceilings. It consists of the BR-1 and a ceiling mounting adapter.

ATTENTION: with swivel brackets in use, the effective detection range may differ from that indicated in Table 1 – the vertical adjusting scale.

3.5 Battery Installation

The SRN-2000W/PCN is powered by a 9-volt alkaline or lithium battery. Remove the detector's front cover, snap the battery clip onto the battery and place the battery in its compartment (below the printed circuit board.). Before testing, allow 10 minutes for the detector to stabilize (the LED may light during this time).

Warning! For proper operation, use only alkaline or lithium type batteries.

3.6 System Code Selection

The code selector consists of an 8-key DIP switch (see Figure 10). Each key is set to either ON or OFF position to create a unique digital system code combination (256 possibilities).

Select the desired digital code so that it will match the one selected on the companion receiver.

All wireless PIR detectors and the receiver used in the alarm system must be set to the same digital code.

CAUTION: The code combination 2, 4, 5, 6, 7 ON / 1, 3, 8 OFF is a factory setting that must be avoided. Also avoid codes such as all keys ON, all keys OFF or alternating ON-OFF settings.

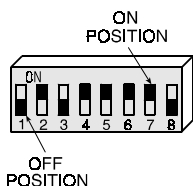

Figure 10. System Code Selector

3.7 Channel Code Selection

The Visonic Ltd. wireless security systems have a multi-channel capability. Each wireless SRN-2000W/PCN detector can be set to transmit one of 4 different channel codes. Each channel code activates a particular output circuit of the companion receiver.

This feature is very useful for zoning purposes - activation of different type of zones at the control panel.

The channel selector consists of a 4-key DIP switch (see Figure 11). The channel code is selected by setting the key with the desired channel number to ON.

If there is a low battery condition, a LOW BATTERY alert code (code "0") will be automatically transmitted once every 2 minutes, regardless of the channel selector setting. Code "0" causes receivers equipped with a buzzer output to activate the buzzer. Setting the 4 channel keys to OFF and initiating a transmission is a way to check whether code "0" works.

Once the detector's tamper switch is activated (by removing the front cover), channel code "2" will be automatically transmitted once every 2 minutes, regardless of the channel selector setting.

Caution: Do not select channel 2 as the normal alarm channel, because this will cause alarm and tamper events to have the same channel code.

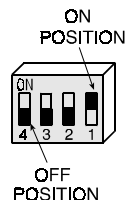

Figure 11. Channel Code Selector

3.8 Adjusting the Coverage Area

A. Horizontal Adjustment

The coverage pattern can be adjusted horizontally approximately ±15° by shifting the lens left or right. Just remove the lens retainers, carefully shift the lens to the desired position and re-lock the lens (see Para. 3.1).

B. Vertical Adjusting Scale

The vertical scale (on the left edge of the p.c. board) and the plastic pointer on the base indicate (in degrees) the vertical angle

between the upper layer of the coverage pattern and the horizontal line of the unit.

Table 1 gives the recommended scale adjustment for various combinations of mounting height and coverage distance. The scale enables pattern adjustment from +10° to -15°, according to the installation height and the required coverage range.

Table 1. Vertical Adjustment

Mounting Height ft ⇒ ↓ m	Coverage Range															
	7	10	13	17	20	23	26	30	33	40	50	60	80	100		
2	0.6	+8°	+6°	+5°	+4°	+3°	+2°	+2°	+2°	+2°	+1°	+1°	+1°	0°	0°	
3	1	0°	0°	0°	0°	0°	0°	0°	0°	0°	0°	0°	0°	0°	0°	
4	1.2	-8°	-6°	-5°	-4°	-3°	-2°	-2°	-2°	-2°	-1°	-1°	-1°	0°	0°	
5	1.5	-	-12°	-9°	-7°	-6°	-5°	-5°	-4°	-4°	-3°	-2°	-2°	-1°	-1°	
6	1.8	-	-	-14°	-11°	-9°	-8°	-7°	-6°	-5°	-5°	-4°	-3°	-2°	-2°	
7	2	-	-	-	-13°	-12°	-10°	-9°	-8°	-7°	-6°	-5°	-4°	-3°	-2°	
8	2.5	-	-	-	-	-15°	-13°	-11°	-10°	-9°	-7°	-6°	-5°	-4°	-3°	
10	3	-	-	-	-	-	-	-	-14°	-12°	-10°	-9°	-7°	-5°	-4°	
12	3.6	-	-	-	-	-	-	-	-	-15°	-12°	-10°	-8°	-7°	-5°	
14	4.2	-	-	-	-	-	-	-	-	-	-15°	-13°	-10°	-8°	-6°	
17	5	-	-	-	-	-	-	-	-	-	-	-	-14°	-10°	-8°	

Example: If you require coverage range of 40 ft (12 m) and wish to install the sensor at a height of 6 ft (1.8 m) from the ground, set the Vertical Adjustment Scale to -5°.

Use the table only to the maximum range of the selected lens, as indicated in the lens library catalog.

All SRN-2000W/PCN sensors are factory preset to -5°. To change the vertical-pattern adjustment, loosen the screw which fastens the printed circuit board to the base. Slide the p.c. board up or down to the desired angle and tighten the screw firmly.

C. Beam Masking Material

A masking material sheet supplied with each detector can be used to mask individual segments in the lens that face potential sources of false alarms (heaters, blowers, pets, etc). The material is transparent to visible light but blocks infrared energy.

To block individual beam(s), locate the corresponding segment(s) in the array (the Beam Locator BL-1 may be used for this purpose - see Section 3.11). Cut the masking material to the exact dimensions of the segment(s) to be blocked, remove the backing paper and apply accurately to the inside (smooth) surface of the appropriate segment(s). In some cases, more than one layer may be required to completely block the infrared energy.

3.9 Setting the Pulse Counter

The programmable pulse counter can be set to count 1, 2, 3 or 5 pulses before activating the alarm relay. This is done by placing the jumper at the desired setting (1, 2, 3 or 5).

5 Pulses: Used in very hostile conditions where many sources, such as rats or flying birds, produce frequent and repeated disturbances. This setting is unsuitable for normal environments.

3 Pulses: This setting provides the maximum protection against false alarms caused by all types of disturbances that may occur in normal environments.

Three pulses may be selected where wide-angle, multi-beam lenses are used - such as illustrated in Sections 1, 2, 3, 6 and 7 of the SUPER-RED Lens Library (except for lens No. 53). The unit will not alarm unless it registers 3 pulses within approximately one minute. This requires crossing more than one beam (each dual-beam produces two pulses. One additional beam element has to be entered to provide the third pulse).

Note: Three pulses should never be used with lens No. 53 or with the long-range lenses included in Sections 3.1 and 3.2 of the Lens Library.

2 Pulses: This setting can be used to increase immunity to false alarms with long-range or low-density lenses (which normally require one-pulse setting). However, if you choose 2 pulses in long-range applications, be sure to do it only in temperature-controlled locations, and where actual room size is significantly less than the range specified for the lens in use.

1 Pulse: This setting actually disables the pulse counter. An alarm is activated on the first detected pulse. One pulse should be selected when using the long-range lenses illustrated in Sections 4 and 5 of the Lens Library, when using lens No. 53, or in high-security installations where fast "catch" performance is of highest importance.

3.10 Final Testing

Overriding the Rearm Timer

Since battery saving is of utmost importance in normal use of the detector unit, an automatic timer inhibits the detector for approximately 2 minutes after each transmission. During this period, the transmitter cannot be triggered again by subsequent motion within the protected area. The detector is automatically rearmed 2 minutes after the last motion was detected.

For rapid walk testing of each beam in the coverage pattern, you must eliminate the 2 minute inhibit interval between successive alarms. The NORM/TEST selector (Figure 7), when set to TEST, overrides the 2-minute rearm timer, and also sets the pulse counter to 1 PULSE. Remember that in the TEST mode, tamper and low battery alerts will be transmitted at 1/2 second intervals instead of the usual 2-minute intervals. When the selector is reset to NORM, the rearm timer reverts to normal operation.

Testing Procedure

- A. Snap the battery clip onto the 9 Volt alkaline or lithium battery and allow ten minutes for the unit to stabilize before testing.
- B. Adjust the vertical calibration angle per Table 1.
- C. Set the Normal/Test selector to TEST.
- D. MASK beams which look at potential sources of false alarms (see Section 3.8, Para. 5).
- E. Replace the cover.
- F. Walk-test the entire protected area by walking slowly across it, observing the LED. The LED lights whenever you cross a protective beam. Allow the unit to restabilize for 5 seconds after each test.
- G. Set the pulse counter according to Section 3.9.
- H. Set the NORMAL/TEST selector to NORM and wait outside the coverage area. After 5 minutes, re-enter the coverage area and verify that the LED lights and that the transmitter output operates (response will be immediate only if the pulse counter is set to **1 pulse**).

If you continue moving within the detector's field of view, the LED will turn OFF and the unit will remain disabled as long as movement continues, due to the 2-minute battery saving rearm timer. The unit will be rearmed provided that no motion is detected for approximately 2 minutes, and will again be ready to detect and signal.

CAUTION: *The range and coverage area of the unit should be checked at least once a year. To assure proper continuous function, the end user should be instructed to perform a walk test at the far end of the area to assure an alarm signal prior to each time the alarm system is armed.*

3.11 Using Beam Locator BL-1

To use the beam locator BL-1, mount the BL-1 on the 3 pins of the special header at the top of the printed circuit board. The BL-1 will cover the pyroelectric detector and its mini-LED will face forward. The mini-LED will light when installed.

Replace the cover. The beam locator LED now projects visible light beams through all lens segments, in the same direction as each corresponding detection beam. Stand within the coverage area, facing toward the PIR and observe the lens.

An illuminated lens segment indicates that you are positioned within the corresponding detection beam of that segment.

By walking through the coverage pattern you can determine the location of all detection beams for precise pattern adjustments or masking of lens segments which are exposed to potential sources of false alarms.

After using the beam locator, take the cover off and remove the BL-1 from the on-board pin header.

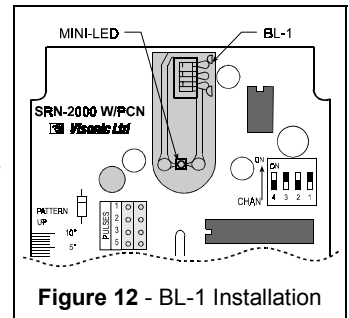

Figure 12 - BL-1 Installation

4. WARNINGS

Visonic Ltd. wireless systems are reliable are tested to high standards. However, due to their low transmitting power (required by FCC and other regulatory authorities), there are some limitations to be considered:

- A. Receivers may be blocked by radio signals on or near their operating frequencies, regardless of the code selected.
- B. Receivers can only respond to one transmitted signal at a time.

- C. Wireless equipment should be tested regularly (at least once a week) to determine if there are sources of interference and to protect against faults.

WARNING! *Changes or modifications to this unit not expressly approved by the party responsible for compliance could void the user's authority to operate the equipment*

WARRANTY

Visonic Ltd. and/or its subsidiaries and its affiliates ("the Manufacturer") warrants its products hereinafter referred to as "the Product" or "Products" to be in conformance with its own plans and specifications and to be free of defects in materials and workmanship under normal use and service for a period of twelve months from the date of shipment by the Manufacturer. The Manufacturer's obligations shall be limited within the warranty period, at its option, to repair or replace the product or any part thereof. The Manufacturer shall not be responsible for dismantling and/or reinstallation charges. To exercise the warranty the product must be returned to the Manufacturer freight prepaid and insured.

This warranty does not apply in the following cases: improper installation, misuse, failure to follow installation and operating instructions, alteration, abuse, accident or tampering, and repair by anyone other than the Manufacturer.

This warranty is exclusive and expressly in lieu of all other warranties, obligations or liabilities, whether written, oral, express or implied, including any warranty of merchantability or fitness for a particular purpose, or otherwise. In no case shall the Manufacturer be liable to anyone for any consequential or incidental damages for breach of this warranty or any other warranties whatsoever, as aforesaid.

This warranty shall not be modified, varied or extended, and the Manufacturer does not authorize any person to act on its behalf in the modification, variation or extension of this warranty. This warranty shall apply to the Product only. All products, accessories or attachments of others used in conjunction with the Product, including batteries, shall be covered solely by their own warranty, if any. The Manufacturer shall not be liable for any damage or loss whatsoever, whether directly, indirectly, incidentally, consequentially or otherwise, caused by the malfunction of the Product due to products, accessories, or attachments of others, including batteries, used in conjunction with the Products.

The Manufacturer does not represent that its Product may not be compromised and/or circumvented, or that the Product will prevent any death, personal and/or bodily injury and/or damage to property resulting from burglary, robbery, fire or otherwise, or that the Product will in all cases provide adequate warning or protection. User understands that a properly installed and maintained alarm may only reduce the risk of events such as burglary, robbery, and fire without warning, but it is not insurance or a guarantee that such will not occur or that there will be no death, personal damage and/or damage to property as a result.

The Manufacturer shall have no liability for any death, personal and/or bodily injury and/or damage to property or other loss whether direct, indirect, incidental, consequential or otherwise, based on a claim that the Product failed to function. However, if the Manufacturer is held liable, whether directly or indirectly, for any loss or damage arising under this limited warranty or otherwise, regardless of cause or origin, the Manufacturer's maximum liability shall not in any case exceed the purchase price of the Product, which shall be fixed as liquidated damages and not as a penalty, and shall be the complete and exclusive remedy against the Manufacturer.

Warning: The user should follow the installation and operation instructions and among other things test the Product and the whole system at least once a week. For various reasons, including, but not limited to, changes in environmental conditions, electric or electronic disruptions and tampering, the Product may not perform as expected. The user is advised to take all necessary precautions for his /her safety and the protection of his/her property.

6/91



VISONIC LTD. (ISRAEL): P.O.B 22020 TEL-AVIV 61220 ISRAEL. PHONE: (972-3) 645-6789, FAX: (972-3) 645-6788
VISONIC INC. (U.S.A.): 10 NORTHWOOD DRIVE, BLOOMFIELD CT. 06002-1911. PHONE: (860) 243-0833, (800) 223-0020. FAX: (860) 242-8094
VISONIC LTD. (UK): FRASER ROAD, PRIORY BUSINESS PARK, BEDFORD MK44 3WH. PHONE: (0870) 730-0800 FAX: (0870) 730-0801
INTERNET: www.visonic.com

©VISONIC LTD. 1998, D-3561-0 NEW : DE3561- (REV. 5, 4/98)



MADE IN ISRAEL